

Project _____
Item _____
Quantity _____
FCSI Section _____
Approval _____
Date _____



Broaster[®] Prep Station



* Buckets and holding pans for the Extra Crispy Prep Station are sold separately.

Standard Features

- *Convenient and Easy To Use* – stainless steel prep stations help to make your breading process more productive giving you a mobile area to prepare your Extra Crispy Broaster Chicken[®] or Genuine Broaster Chicken[®].
- *Minimize Waste* – by controlling your breading usage.
- *Sturdy and Durable* – stainless steel work surfaces are easy to clean after each use.

85837 Extra Crispy Prep Station

This prep station features a smaller footprint, allowing you to put this prep station almost anywhere. It could be put right on the line or be rolled back into a walk-in refrigerator to refrigerate the coating and slurry. The prep station is also complete with two tray slots for additional pan storage.

Includes: One basic station, four swivel casters two locking

Options: 12 quart bucket & lid, holding pans

85405 Extra Crispy High Volume Prep Station

This prep station is designed for a higher volume operation or an operation that is looking for more efficient use of their breadings. The prep station has a built-in sifter which allows you to sift breading into the lower container, thus giving you more efficient use of your breadings. The containers also include lids to help reduce the risk of contamination. The extension shelves on this unit make it easier to bread and load product into the Broaster pressure fryer.

Includes: One basic station, two extension shelves, one pan shelf, rotary sifter, two 12.5 gallon tubs, one caster kit, four swivel casters two locking

Options: Leg kit, right side shelf without hole, 12 quart bucket & lid

Broaster® Prep Station

Dimensions

Dimensions			Overall Dimensions		Net/Ship Weight 115/125 lbs. (kg)
W	D	H	W	H	
28.75"	20.63"	36.13" to tabletop	54.63"	54.38"	
(727)	(527.1)	(914.4)	(1441.5)	(1371.6)	

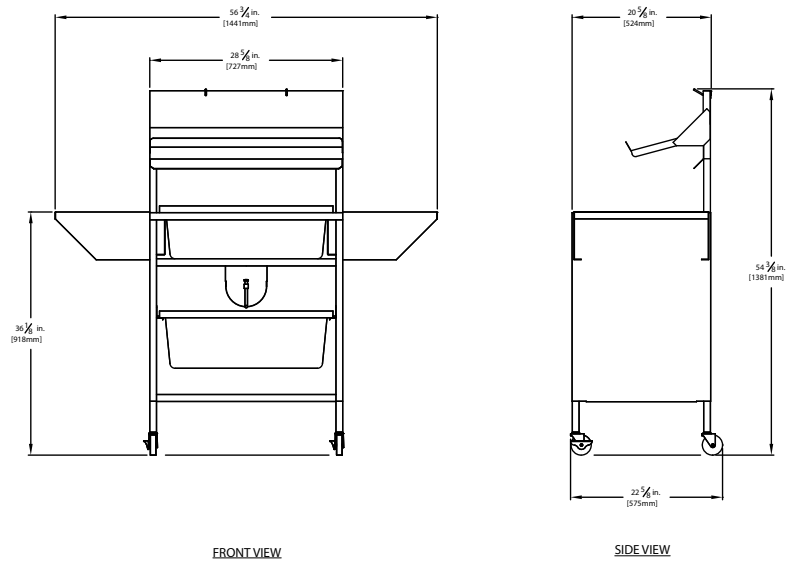

Dimensions

Dimensions			Net/Ship Weight 43/47 lbs. (kg)
W	D	H	
16.88"	27.63	35.88" to tabletop	
(429)	(702)	(911)	

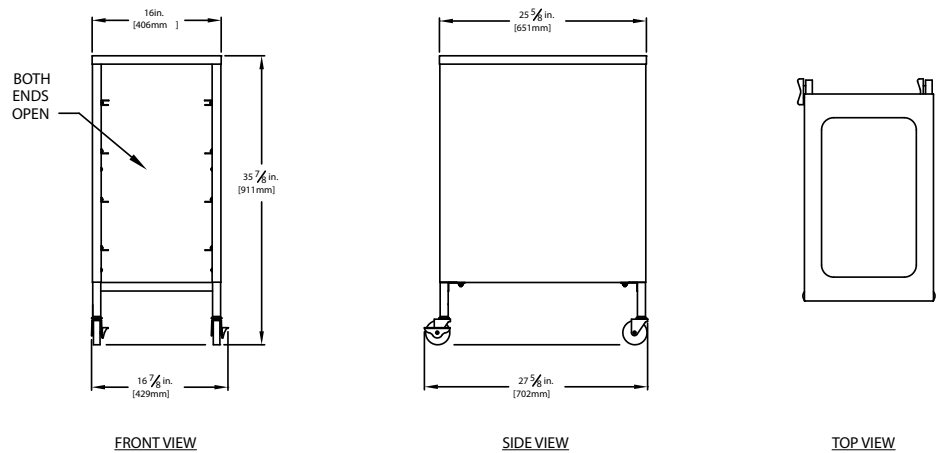

15416 Broaster Extra Crispy Breader Kit



This accessory kit is ideal for use with the Extra Crispy Prep Station. The kit includes everything you need to prepare ExtraCrispy Broaster Chicken including a sifter for more efficient use out of your breadings.

Kit Includes: Wire whip, sifter, 1 cup measuring cup, pitcher, 12 quart bucket & lid, 12 quart breadng box & lid, and disposable foodservice gloves.

11853 Basic Prep Station

Extra Crispy High Volume Prep Station excluding the extension shelves and one pan shelf.