



Broaster[®] Metal Module



Standard Features

- *Branded look* – whether you're remodeling your existing counter space or constructing a new facility, these Broaster metal modules are the ideal way to give your operation a professional, branded appearance.
- *Coordinated look* – designed to perfectly complement our Perfect Hold countertop and complete deli cases for customizing your in-line or kiosk set-up in the Broaster color scheme.
- *Perfect fit* – available in four foot and six foot versions to fit your needs.
- *Durable construction* – made of aluminized, powder-coated steel with a stainless steel countertop surface.
- *Optional built-in backlit graphics* – standard *Broaster® To Go* graphics panel can be backlit with optional UL approved 3-bulb fluorescent light unit (power cord is included; 120 volt/1 phase/60 hertz/0.6 amp electrical requirement).

Specifications

Free standing metal module is of welded, powder-coated steel construction with full-coverage stainless steel countertop surface. Unit includes single master power supply featuring backlit display graphic panel.

Broaster® Metal Module

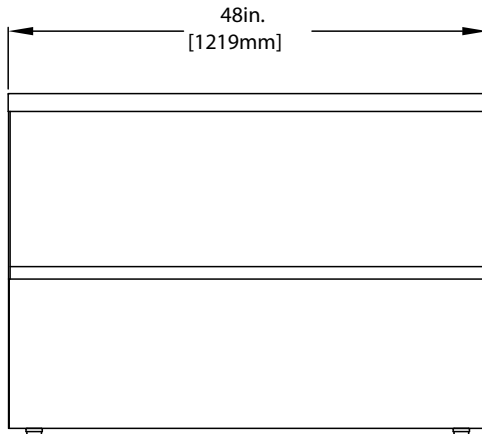

FRONT VIEW

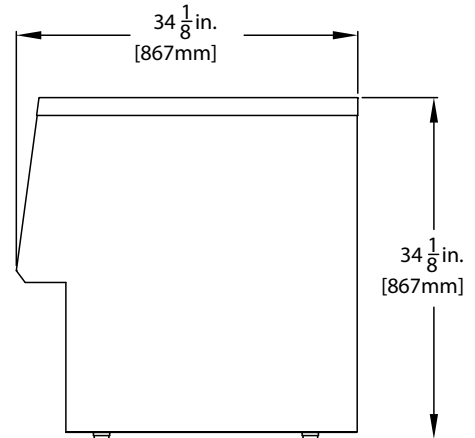

END VIEW

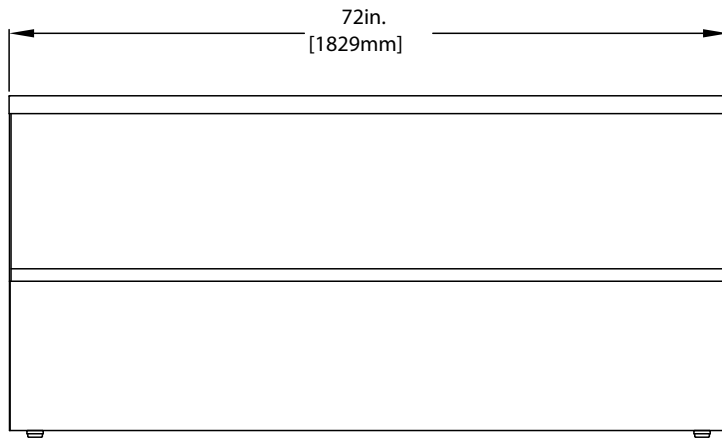

FRONT VIEW

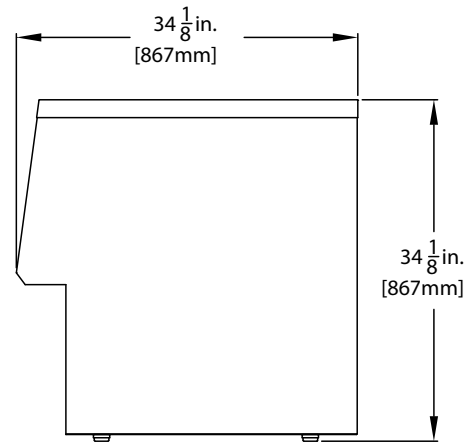

END VIEW

Dimensions

Part Number	Overall Dimensions			Net/Ship Weights
	W	D	H	
85910 85911 (backlit)	48" (1219 mm)	34-1/8" (867 mm)	34-1/8" (867 mm)	180/200 lbs. (82/91 kg)
85912 85913 (backlit)	72" (1829 mm)	34-1/8" (867 mm)	34-1/8" (867 mm)	

Accessories & Options Available

- Half and full-length middle storage shelves