

BROASTER[®]
EQUIPMENT

Broaster[®] Pressure Fryer - 1600



Standard Features

- *Fast and productive* – specifically designed for high volume production, cooks up to 20 pieces of fresh bone-in chicken per load in under 10 minutes.
- *Unique Pressure Activated Cover Locking Mechanism* – quick closing and opening single action sealing including a pressure-activated cover locking mechanism for safety and ease of use.
- *Proven round cooking well design* – engineered for more uniform heat distribution, durability, and efficiency; no cold spots or corners. Large capacity provides more room for product, minimizes sticking, and produces delicious, superior quality food.
- *Fully Welded Cooking Well* – made from durable 300 Series Stainless Steel.
- *Easy to operate* – Temp-N-Time™ feature offers the capability to pre-program up to 10 different cook cycles for quick and easy preparation of various menu items. Solid-state controller is backed by a 2-year warranty.
- *Unique Auto Comp™ feature* – automatically adjusts cooking time to accommodate for varying sizes and temperatures of loads.
- *Automatic cook cycle counter* – monitors production between filtering.
- *Built-in filter system* – provides quick, easy, and safe cooking oil filtration; no heated fittings to disconnect.
- *Touch screen controller option available.*



Specifications

Primary construction is of stainless steel built on powder-coated steel frame with chrome-plated front leveling feet. Rear legs are fitted with casters on electric models and stainless steel feet on gas fired models.

Round cooking well with 21 pound cooking oil capacity operates between 12-14 psi gauge pressure at temperatures up to 375°F.

Triple-redundant safety system is featured consisting of stainless steel relief valve, stainless steel splash guard and single action patented cam lock cover system with pressure regulator interlock. Also has single action combined pressure regulator valve/remote timer control, drain valve interlock and pressure activated cover locking mechanism. All ensure operator convenience and safety.

Solid state Temp-N-Time™ controller provides 10 programmable cooking profiles with built-in, automatic cook-cycle counter. Auto-Comp feature automatically adjusts cooking time dependent on size and temperature of load.

On-board integrated filtration system consists of easily accessible stainless steel filter tray assembly. Powered by a 1/3 horse-power motor coupled to 5 gallon-per-minute rotary gear displacement oil pump.

Equipment is covered by manufacturer's 1 year parts and labor warranty on all systems, additional 1 year on controller parts and 10 year repair warranty on cooking well.

Broaster® Pressure Fryer – 1600

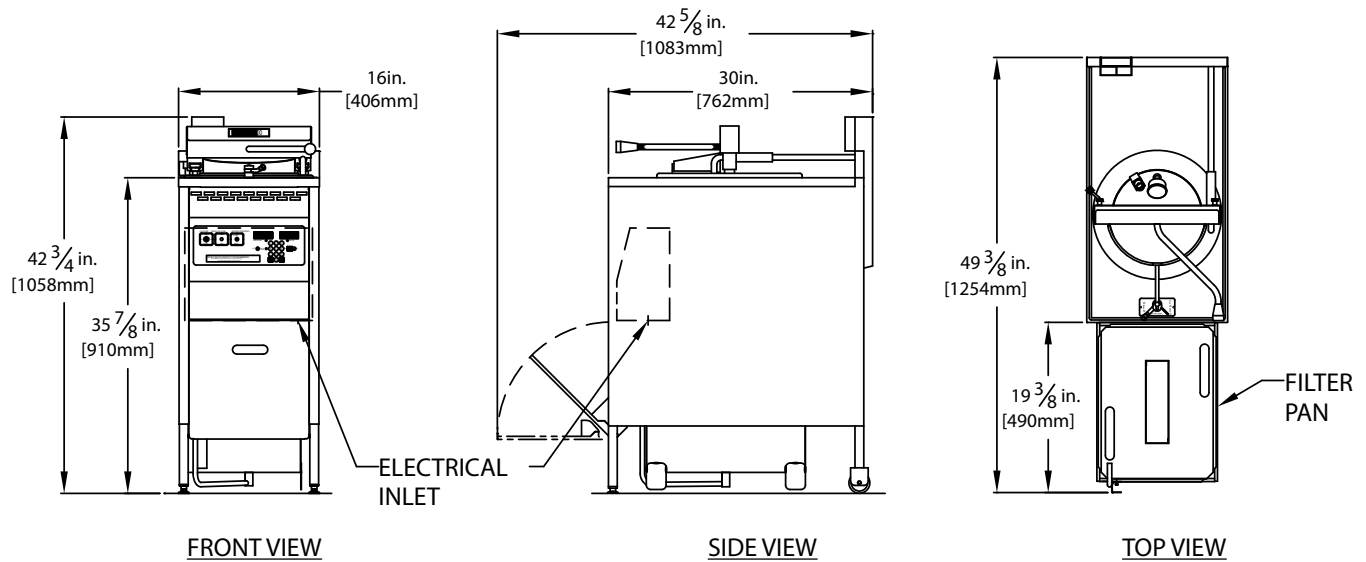

Dimensions

Model	Fresh Chicken Capacity	Cooking Oil Capacity	Operating Pressure	Overall Dimensions			Counter Height	Net/Ship Weight	Cubes
				W	D	H			
1600	7 lbs./load 40 lbs./hour	21 lbs.	12 - 14 P.S.I.	42 3/4"	42 5/8"	35 7/8"	35-7/8" (914 mm)	195/216 lbs.	16.53
				16"	29"	42-3/4"			
				(406 mm)	(737 mm)	(1088 mm)			

Energy Requirements

- 1600** 6kW Rated Heating Elements
- 1 phase, 208 volt, 60 hz, 29 amps
 - 1 phase, 240 volt, 60 hz, 25 amps
 - 3 phase, 208 volt, 60 hz, 17 amps
 - 3 phase, 240 volt, 60 hz, 15 amps
- No cord/plug provided.

Accessories & Options Available

- Basic Accessory Kit
- Complete Start-up Accessory Kit
- Rear Wheels

Additional Features

- Durable, welded, tubular steel frame is powder-coated to resist corrosion.
- Stainless steel top and side panels offer durability and easy cleaning.
- Unique stainless steel basket with a ratchet-style removable basket handle allows easier unloading of product.

Complete Accessory Kit



Basic Accessory Kit

