

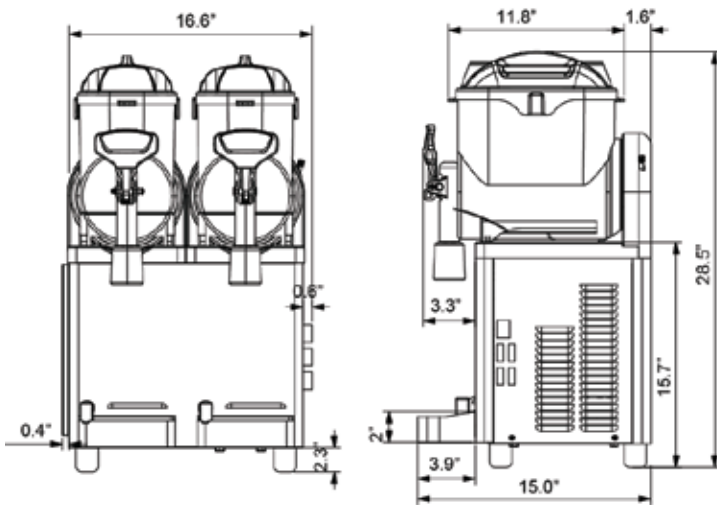

SSM-52



\* Standard Warranty: 1 Year Parts & Labor

REV. 07/03/2023

## Features and Benefits

- Fastest Freezing cycle
- 2.0 gal/bowl capacity
- Durable metal gear motor for long life and reliability
- Dispense a variety of frozen beverages
- Perfect performance in tropical zone
- Classical design
- Easy Maintenance & Cleaning
- Automatic shut down refrigeration control
- Easy removal drip tray

## Specifications

<b>Model</b>	SSM-52
<b>Tank Capacity</b>	2.0 gallon x 2 Bowls
<b>Legs</b>	Rubber
<b>Power Consumption</b>	0.67 HP (500 W)
<b>Gear Motor</b>	67 W x 2
<b>Refrigerant</b>	R134A
<b>Compressor</b>	0.5 HP
<b>Electrical</b> <i>(included power cord with NEMA 5-15 plug)</i>	115V / 60Hz / 1Ph

## Exterior

DIMENSION	MACHINE	SHIPPING
Width	16.6"	19"
Depth	15.0"	18"
Height	26.2"	35"
Weight	83.8 lbs	99 lbs

## Certifications



Design and specifications are subject to change without notice