



ISI-161TH / TI



WARRANTY

- ISI-161TH, ISI-161TI: 1-Year Parts & Labor
- Compressor: 5-Year Parts & 1-Year Labor

** Please note: wearable parts with tune-up kit and scraper blades are not belonging to warranty parts and replaced at least once every three months*

DESCRIPTION

- Slim and compact design
- Direct motor drive: less noise & vibration
- Heat treatment (Pasteurization): ISI-161TH
- Agitator
- Mix low & out sensors

SPECIFICATIONS

Type	Countertop
Flavors	Single Flavor
Cooling	Air Cooled
Electrical	115V / 60Hz / 1Ph
Hopper Capacity	3.2 qt (0.8 gallon)
Cylinder Capacity	1.7 qt (0.4 gallon)
Power Consumption	1.88 HP (1,400 W)
Max. Production	26.5 lbs/h
Consecutive Dispensing	5 cups / 3.5 oz
Compressor - Cylinder	0.85 HP x 1 (R404A)

EXTERIOR

DIMENSION	MACHINE	SHIPPING
Width	12"	15"
Depth	31"	34"
Height	30"	36"
Weight	196 lbs	238 lbs

CERTIFICATIONS



Design and specifications are subject to change without notice

ISI-161TH / TI

MINI ICE CREAM MACHINE

PLAN VIEW

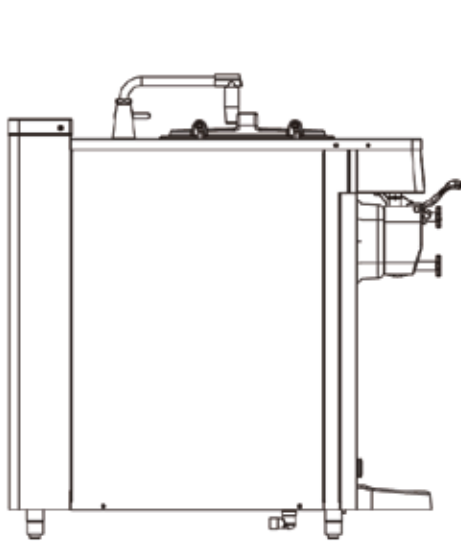

LEFT SIDE

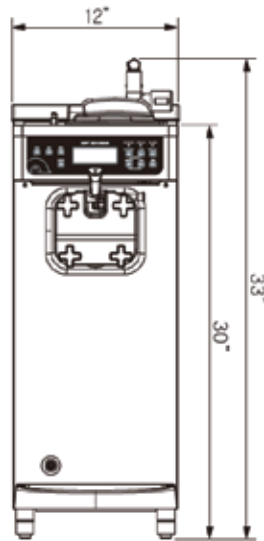

FRONT VIEW

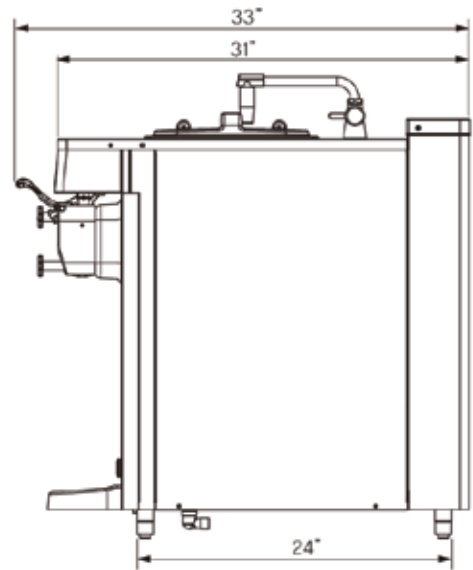

RIGHT SIDE

DETAIL VIEW



Easy to control on the front
LCD touch panel



Agitator
Mix low & out sensors



Air discharge on top

REV. 02/01/2022

Design and specifications are subject to change without notice



mccormackdistributing.com
1755 24th ST SW
Le Mars, IA 51031
1-800-383-5678

McCormack Distributing
Company